

Efficient high quality light management

O. Fernandez

Muttenz, 12.12.2016

CSEM at a glance

Our mission

Development and transfer of microtechnologies to the industrial sector – in Switzerland, as a priority – in order to reinforce its competitive advantage

- Cooperation agreements with established companies
- Creation of start-ups



Lighting

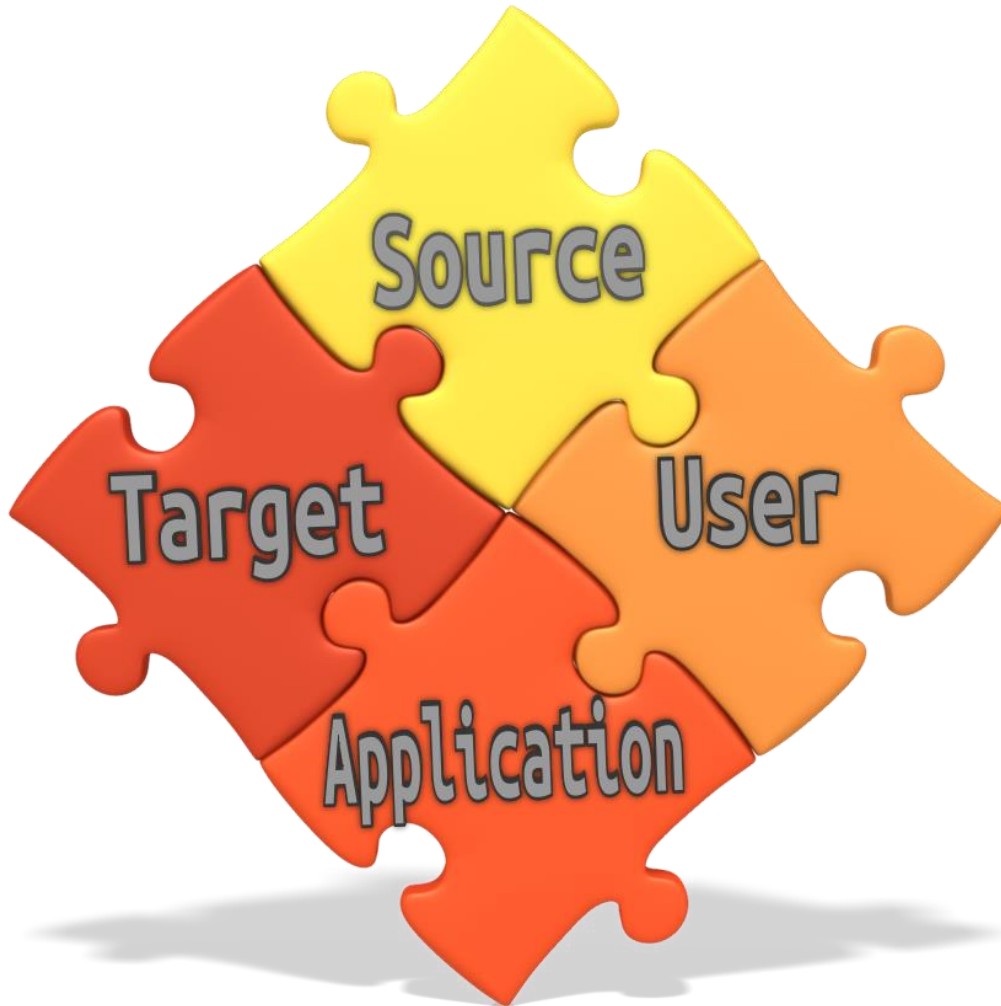

Lighting

The deliberate use of natural or artificial light to achieve a practical or aesthetic effect

Property of the LASSIE-FP7 Consortium

Lighting

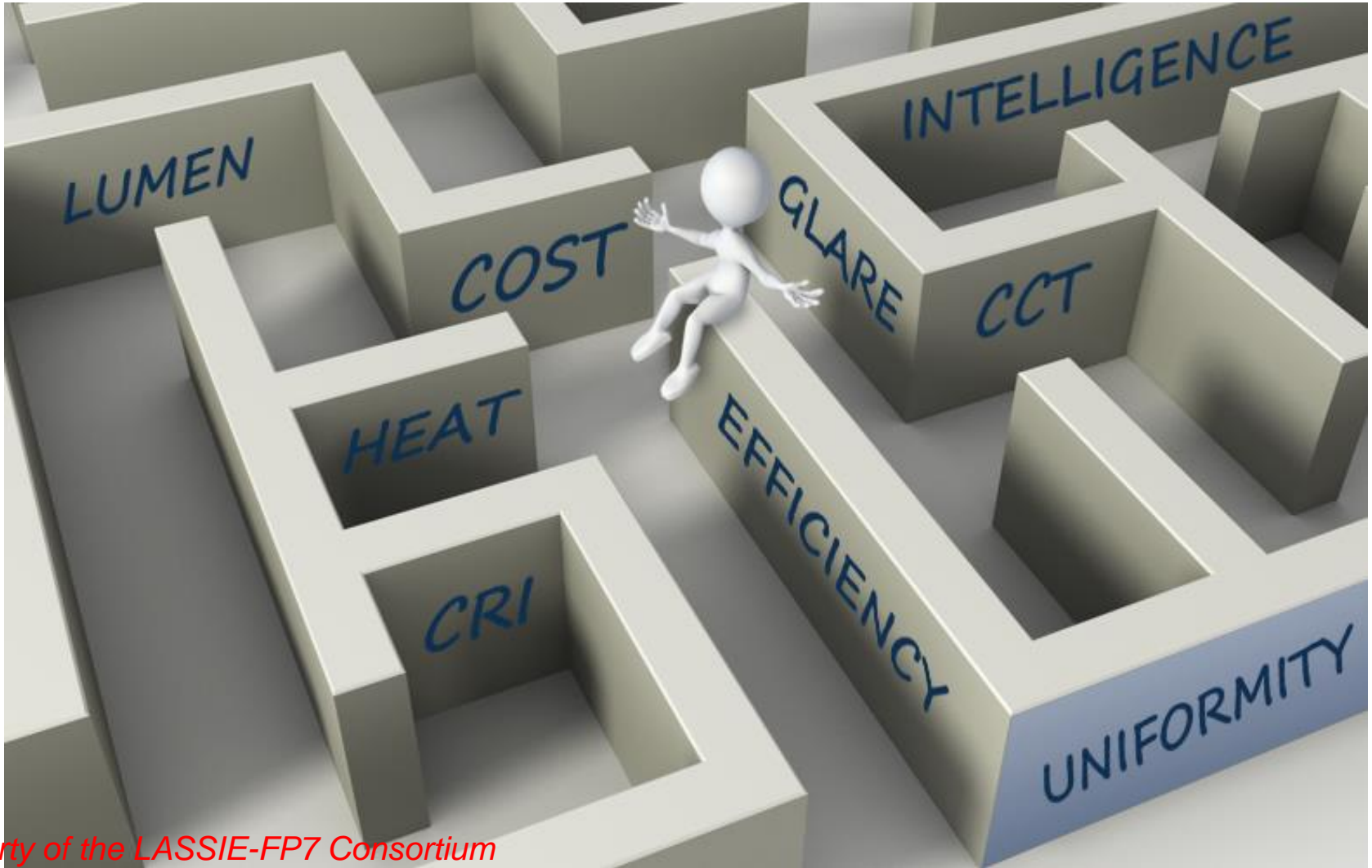

Property of the LASSIE-FP7 Consortium

Artificial light sources

Incandescent



Halogen



Fluorescent



LED



Property of the LASSIE-FP7 Consortium

Why LED technology?



Property of the LASSIE-FP7 Consortium

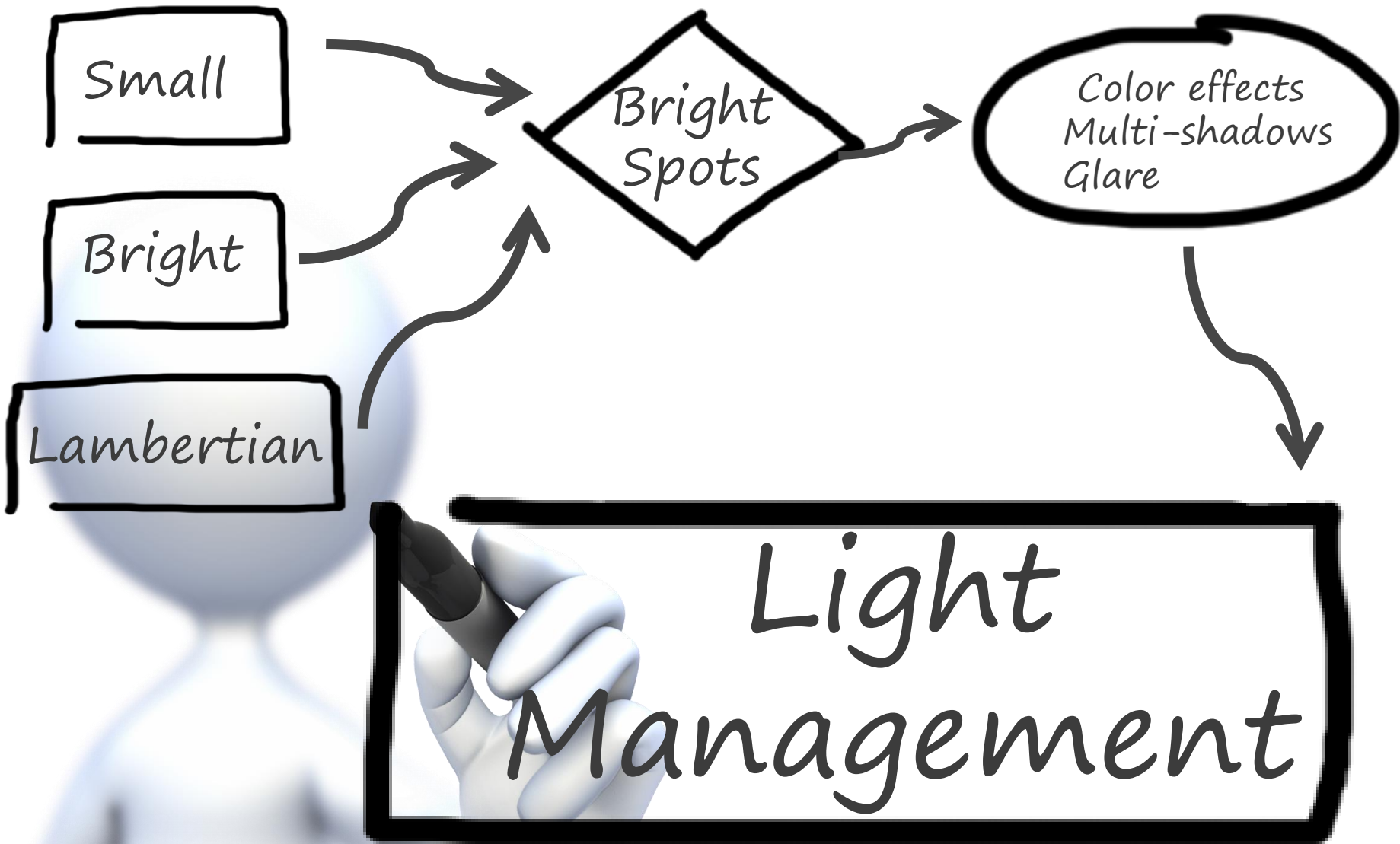

Light Management

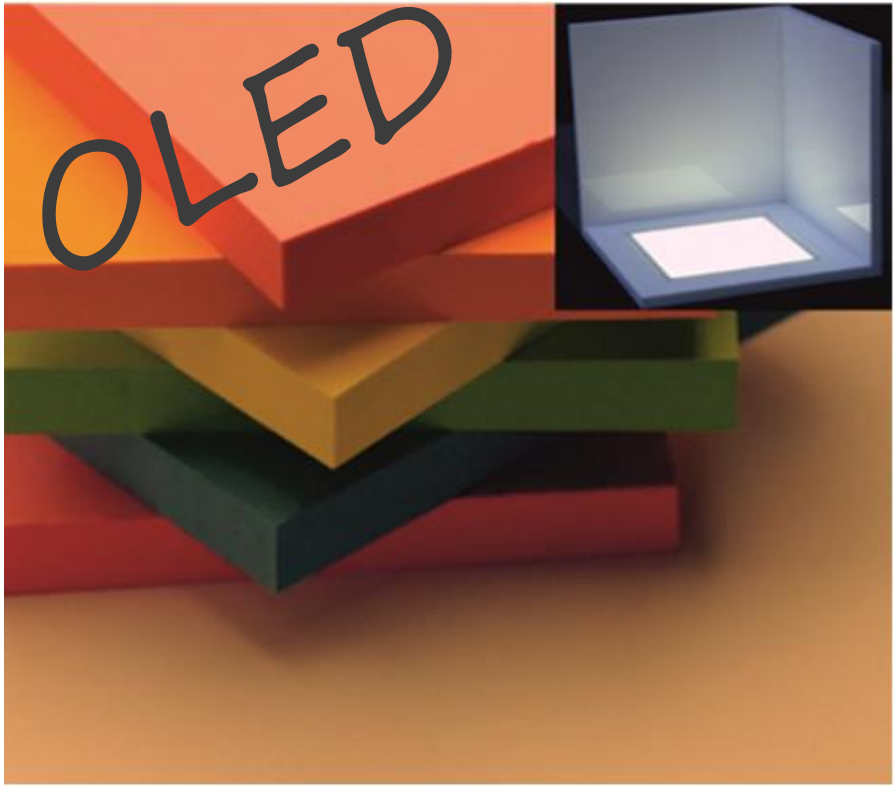

Property of the LASSIE-FP7 Consortium

Large area
Beam shaping
Light mixing

Large-Area LED modules

Direct-lit

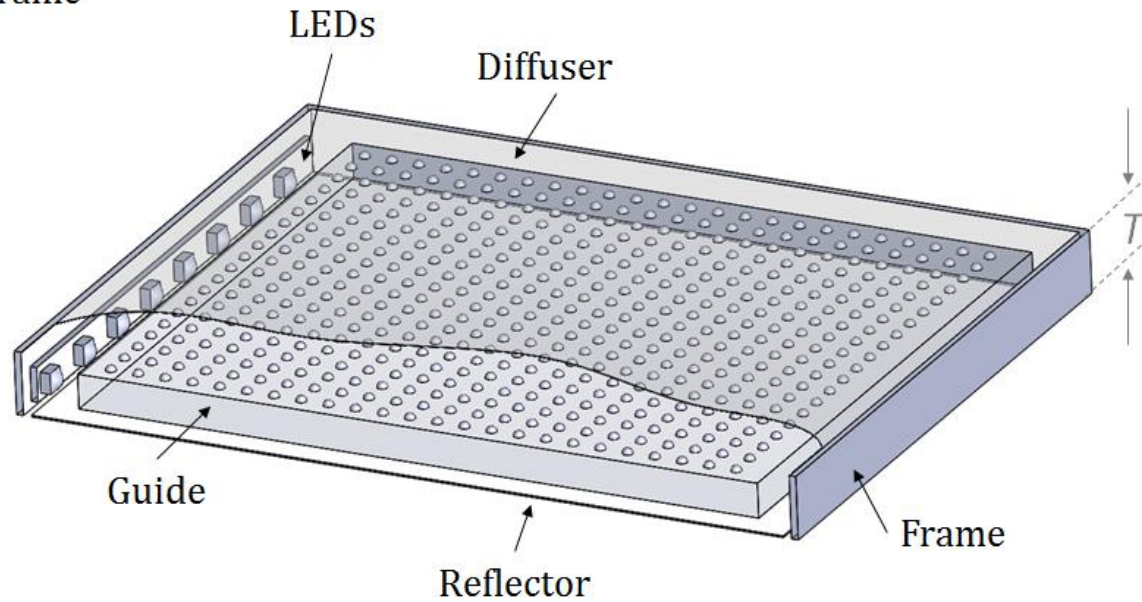
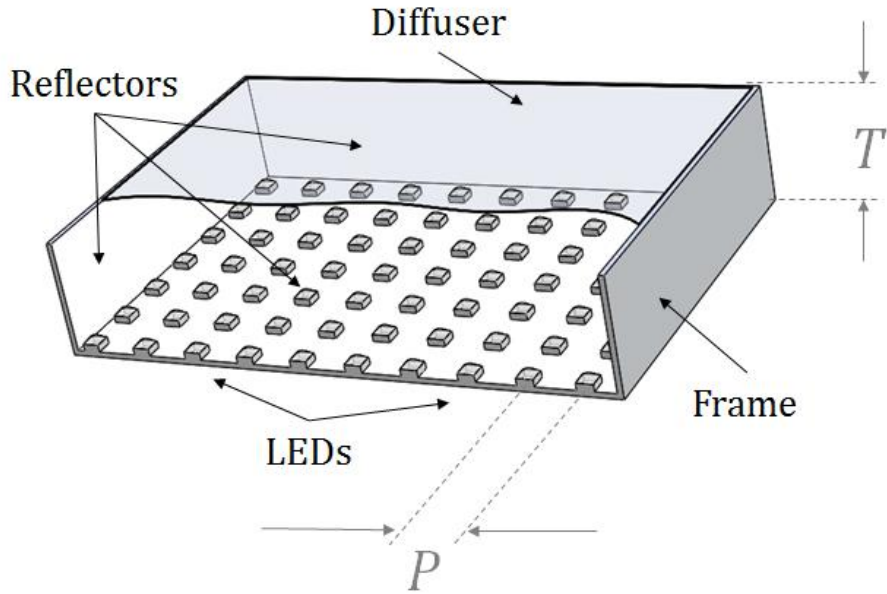

Edge-lit

Property of the LASSIE-FP7 Consortium

Beam-shaping

Radiance distribution

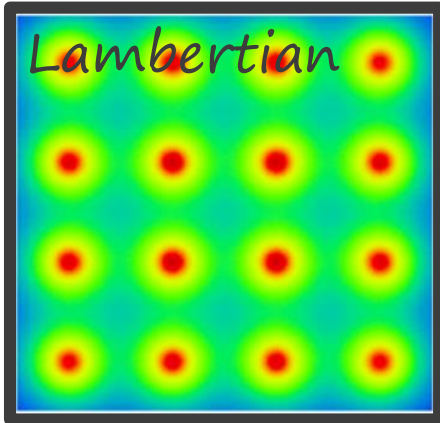

$P=30\text{mm}$; $T=15\text{mm}$

Property of the LASSIE-FP7 Consortium

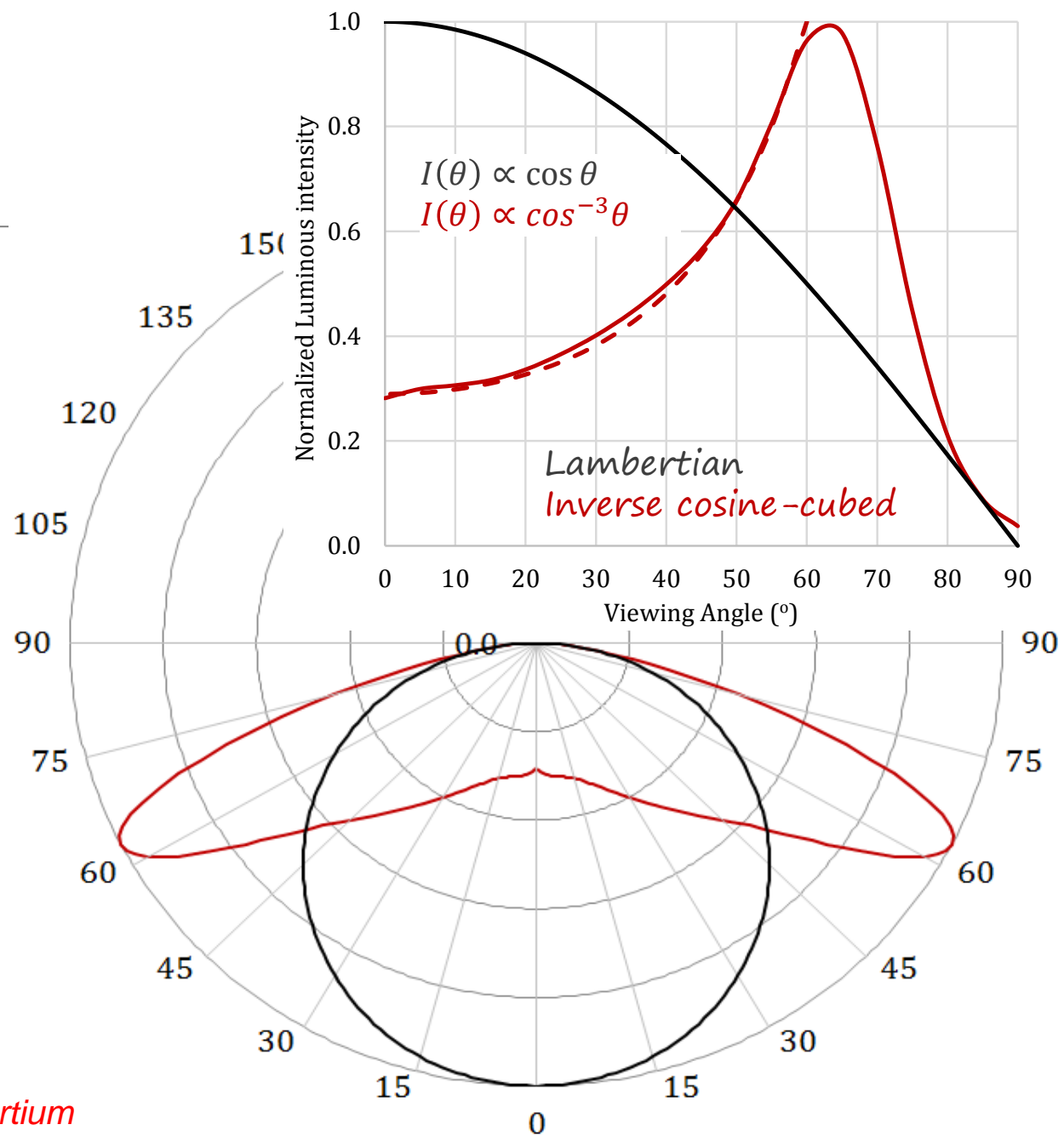

Beam shaping optical pixels

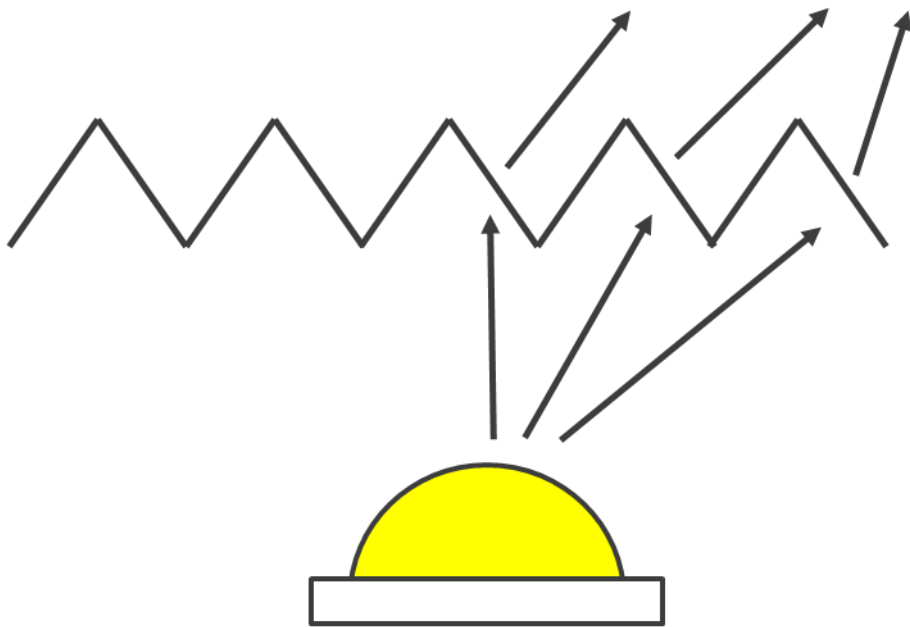

Periodic microstructures

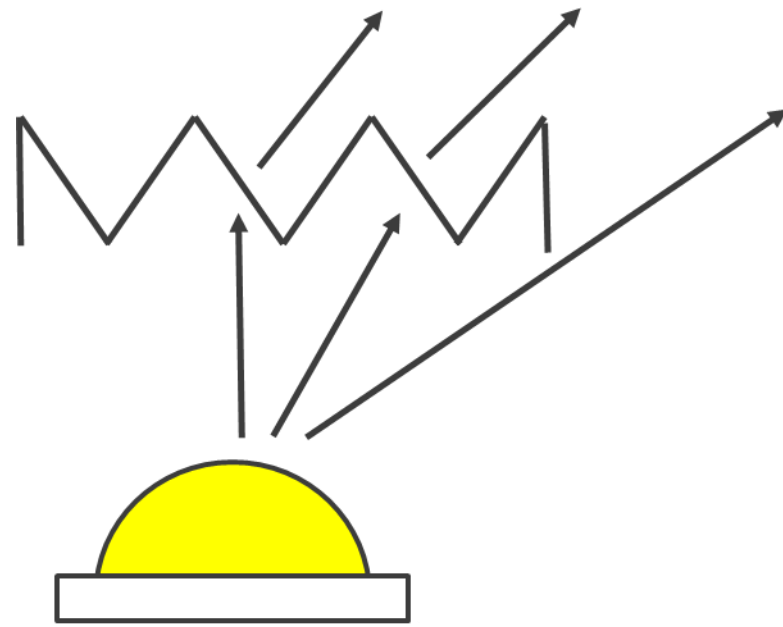

Microstructured pixel

Beam shaping optical pixels

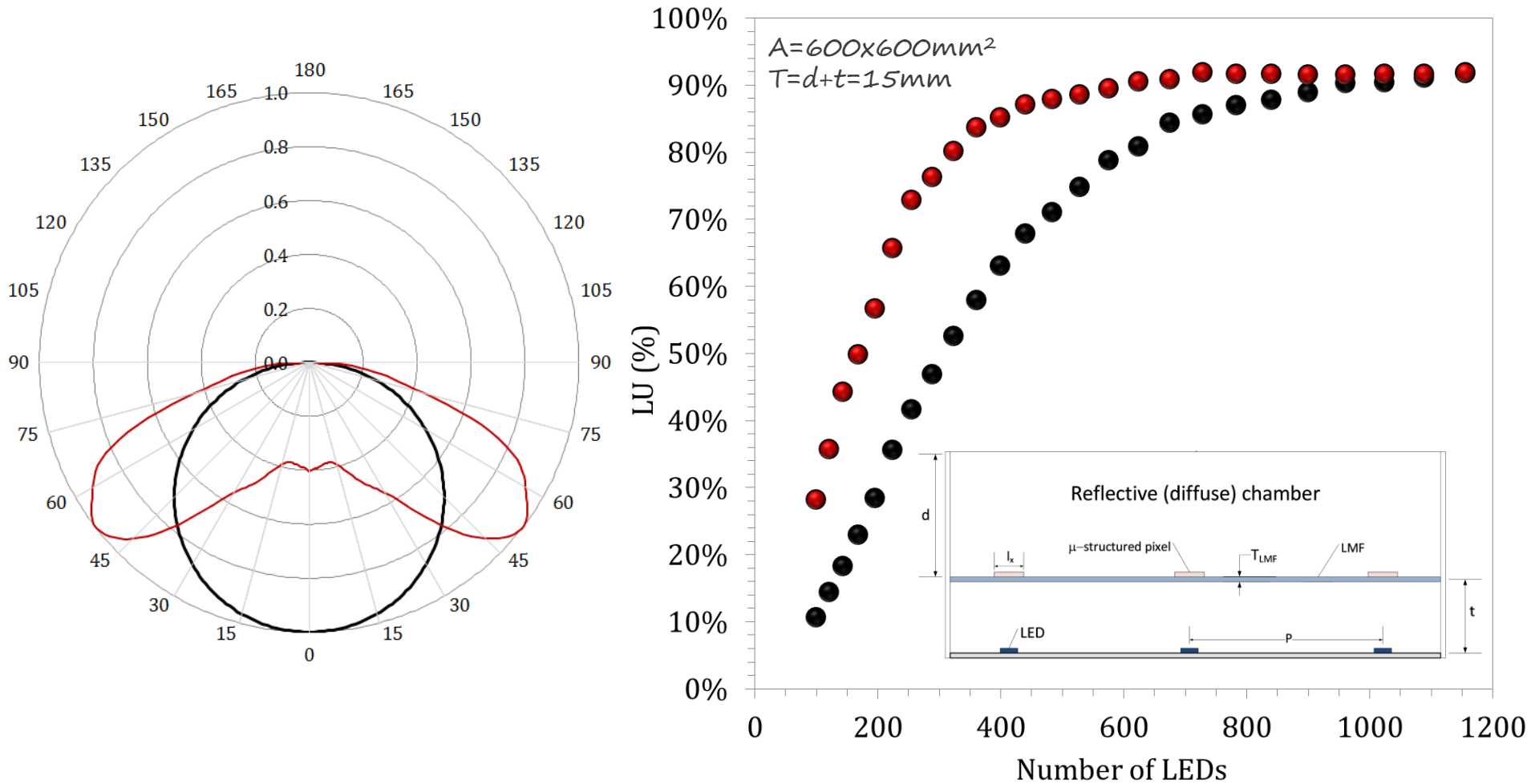

Property of the LASSIE-FP7 Consortium

Light mixing

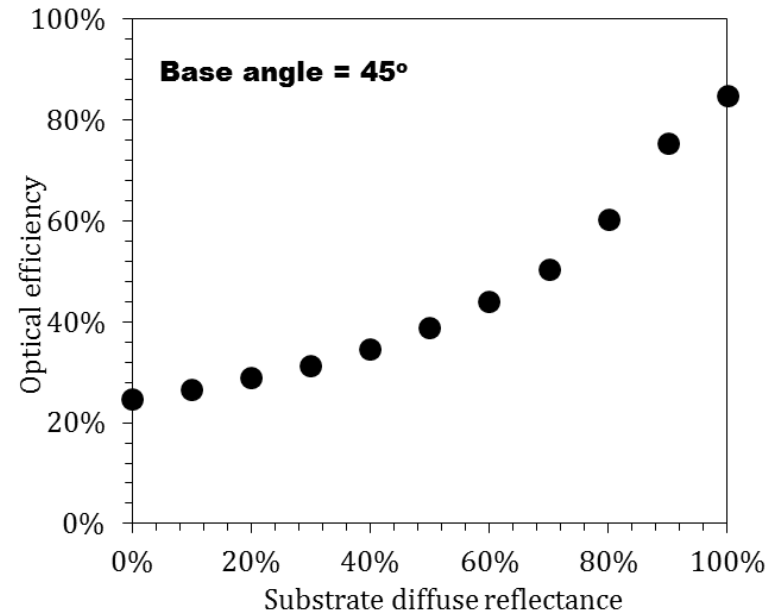
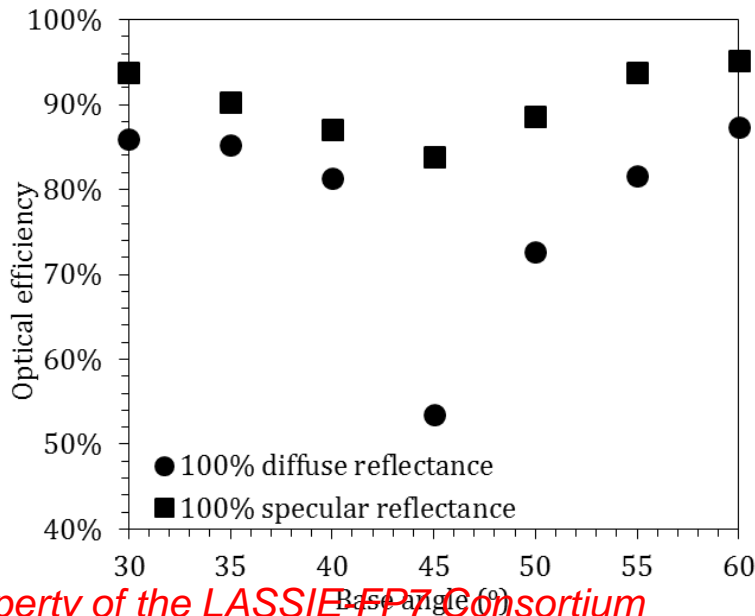
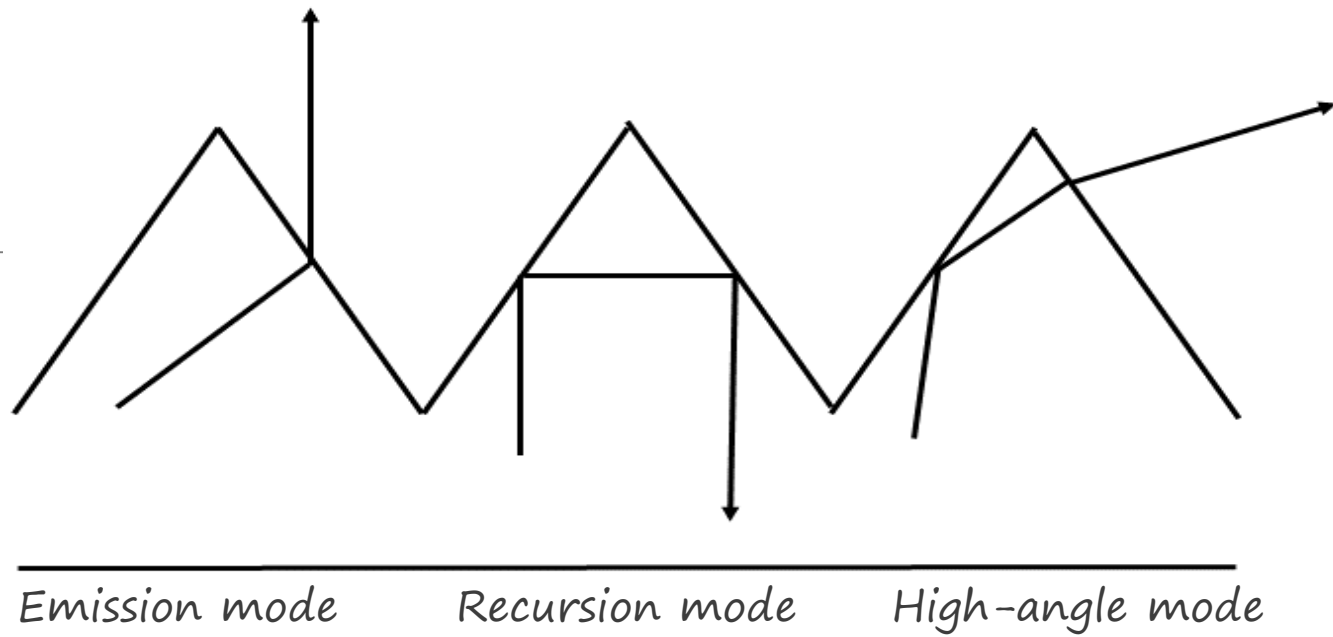

Property of the LASSIE-FPT Consortium

Bright Enhancement Foils (for displays)

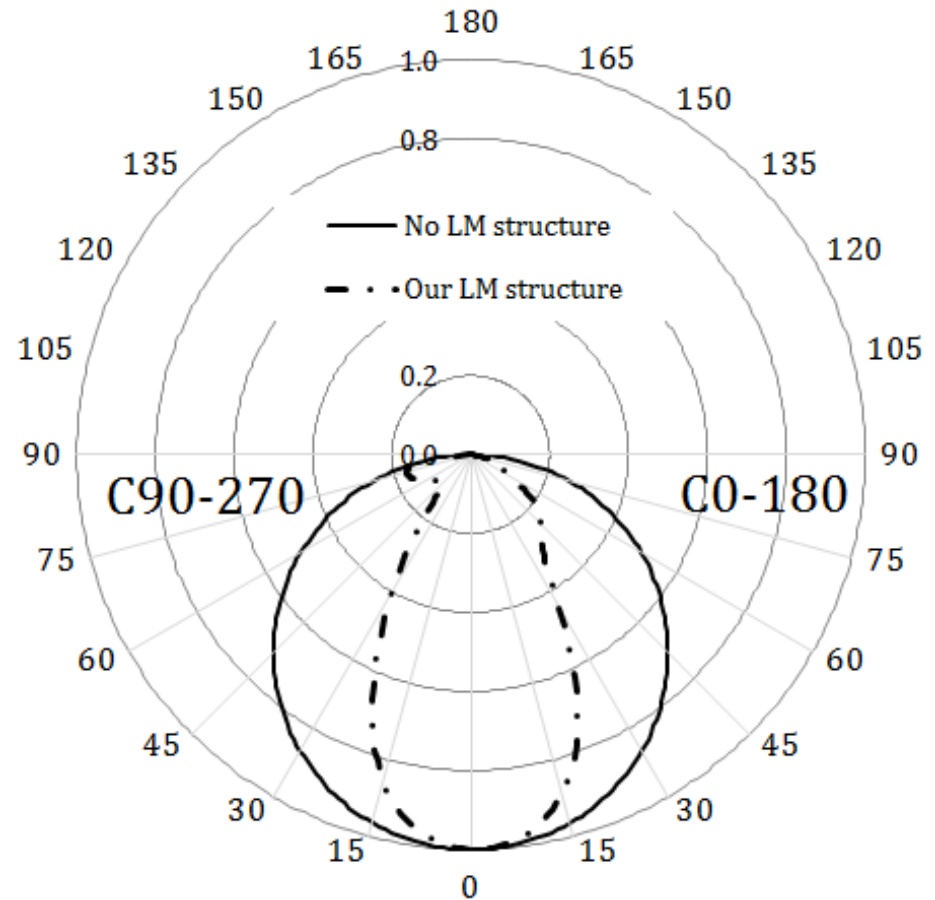
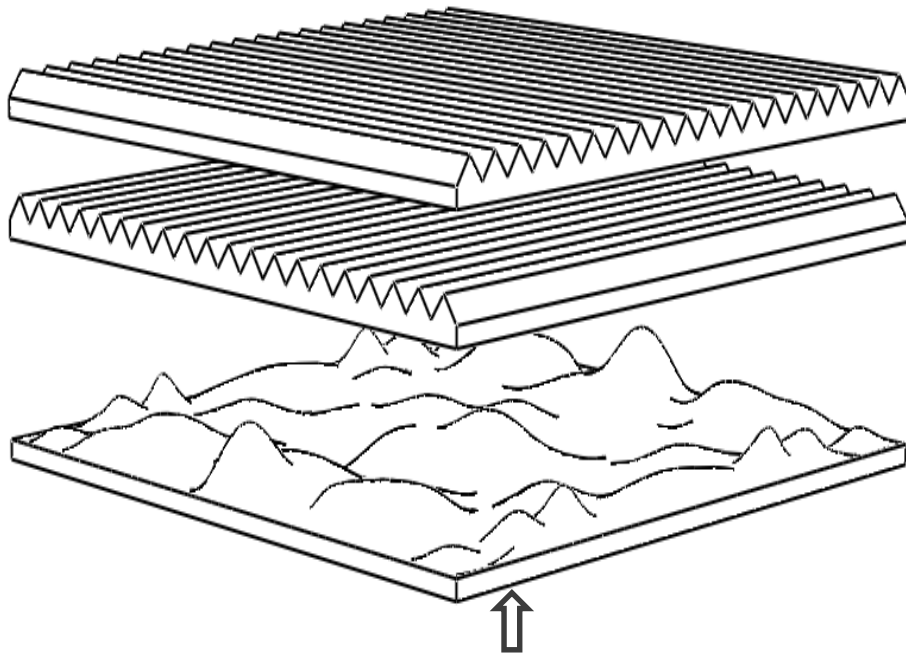

Property of the LASSIE-FP7 Consortium

Bright Enhancement Foils (for displays)



Property of the LASSIE-FP7 Consortium

Bright Enhancement Foils (for displays)

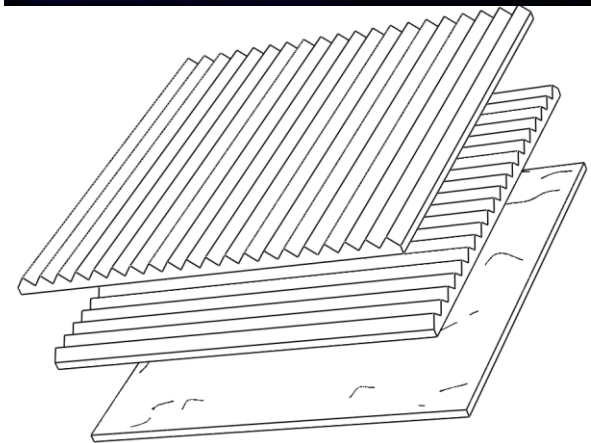
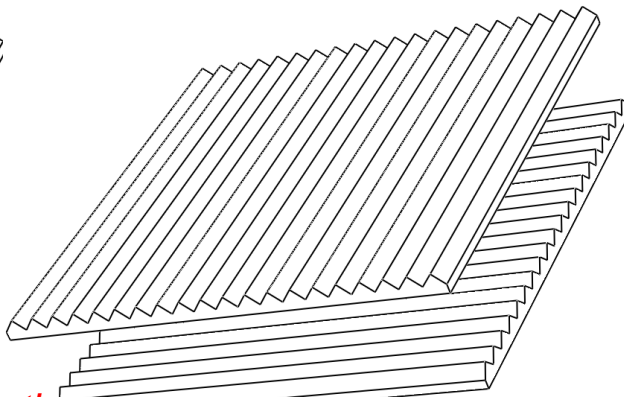
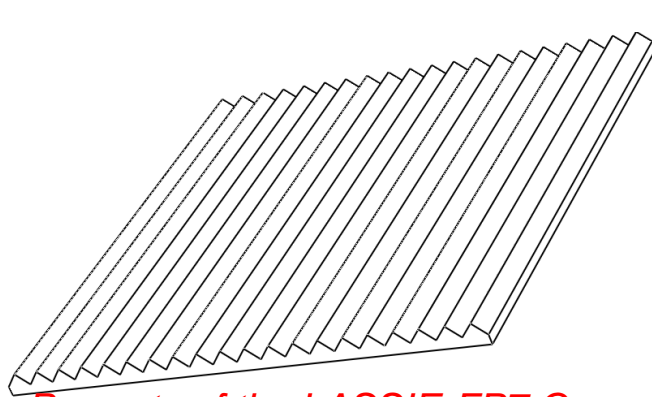
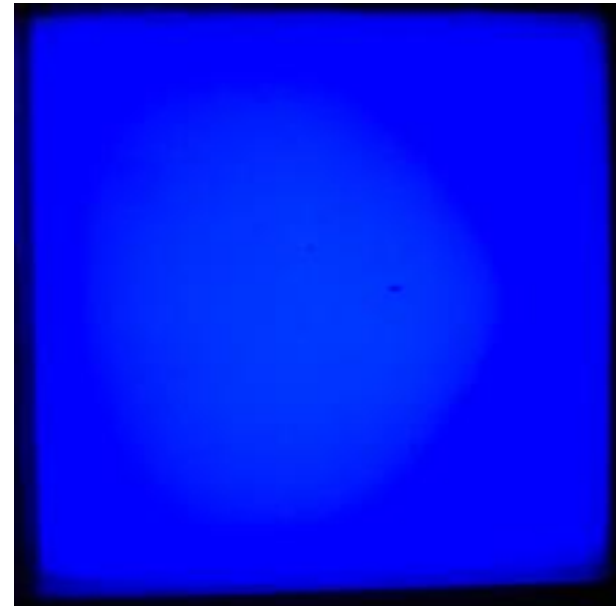
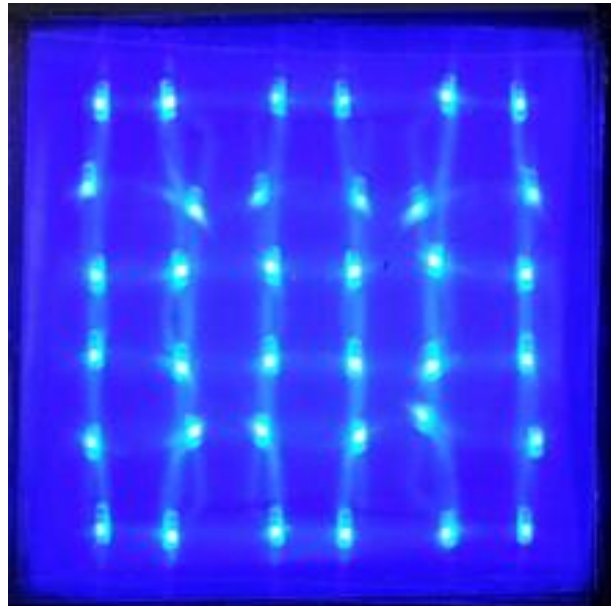
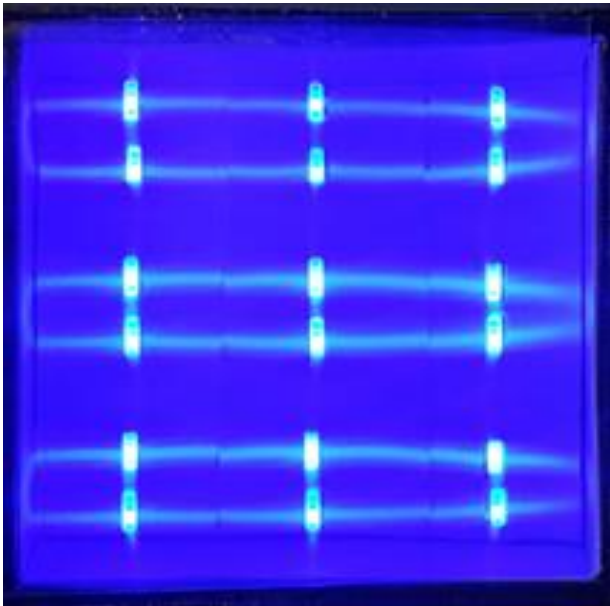

Property of the LASSIE-FP7 Consortium

Light recycling prismatic foils

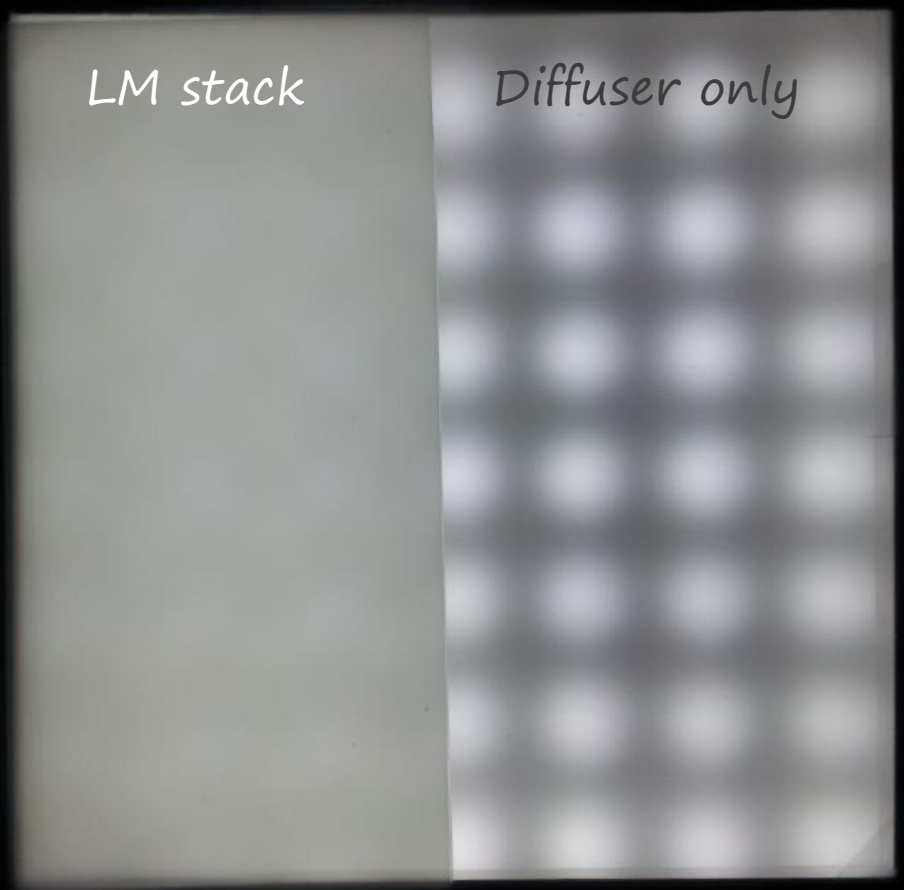

Property of the LASSIE-FP7 Consortium

Multicolor LEDs

Down-conversion

Property of the LASSIE-FP7 Consortium

Multicolour LEDs

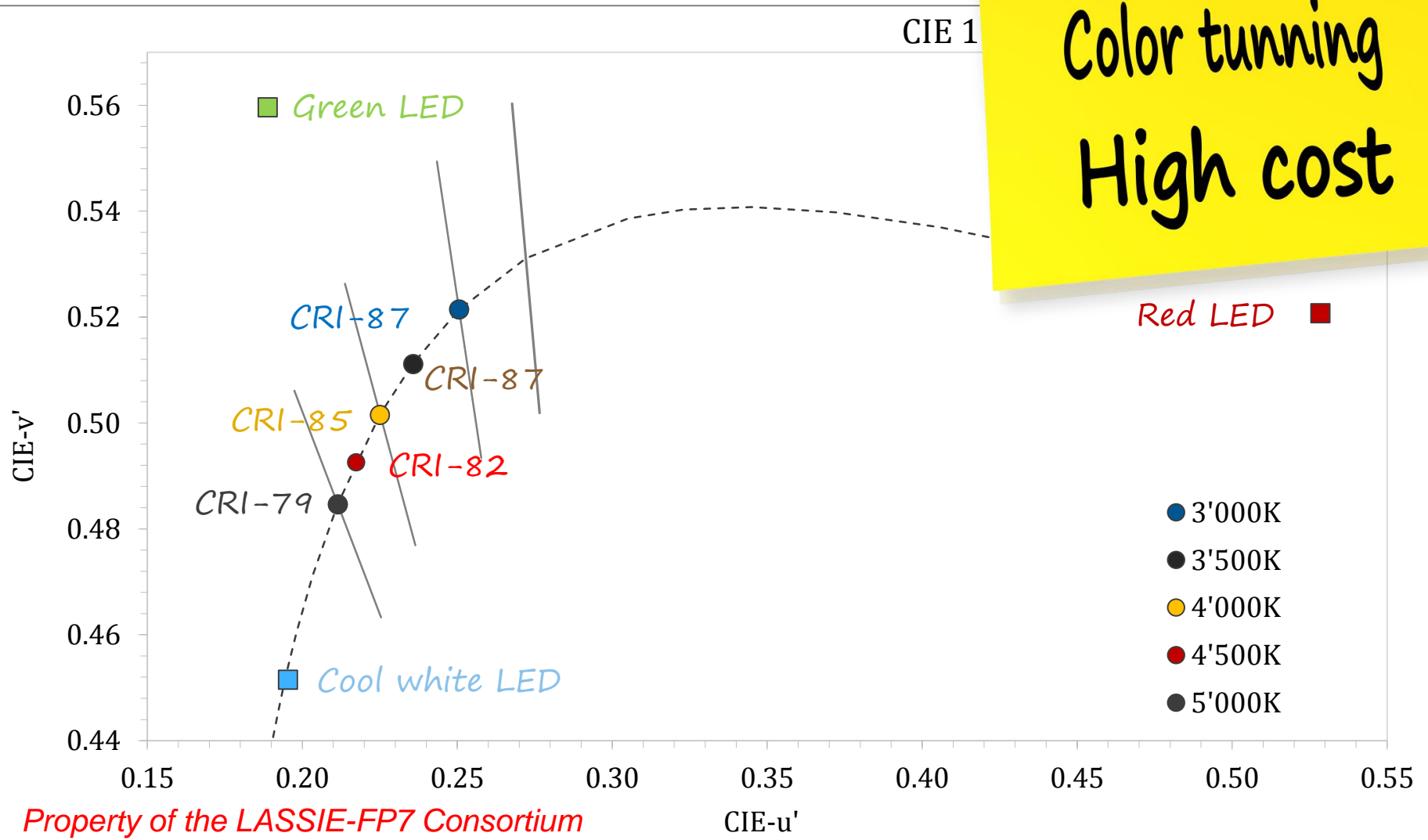

Organic-based down-converting phosphor

High CRI
Low cost

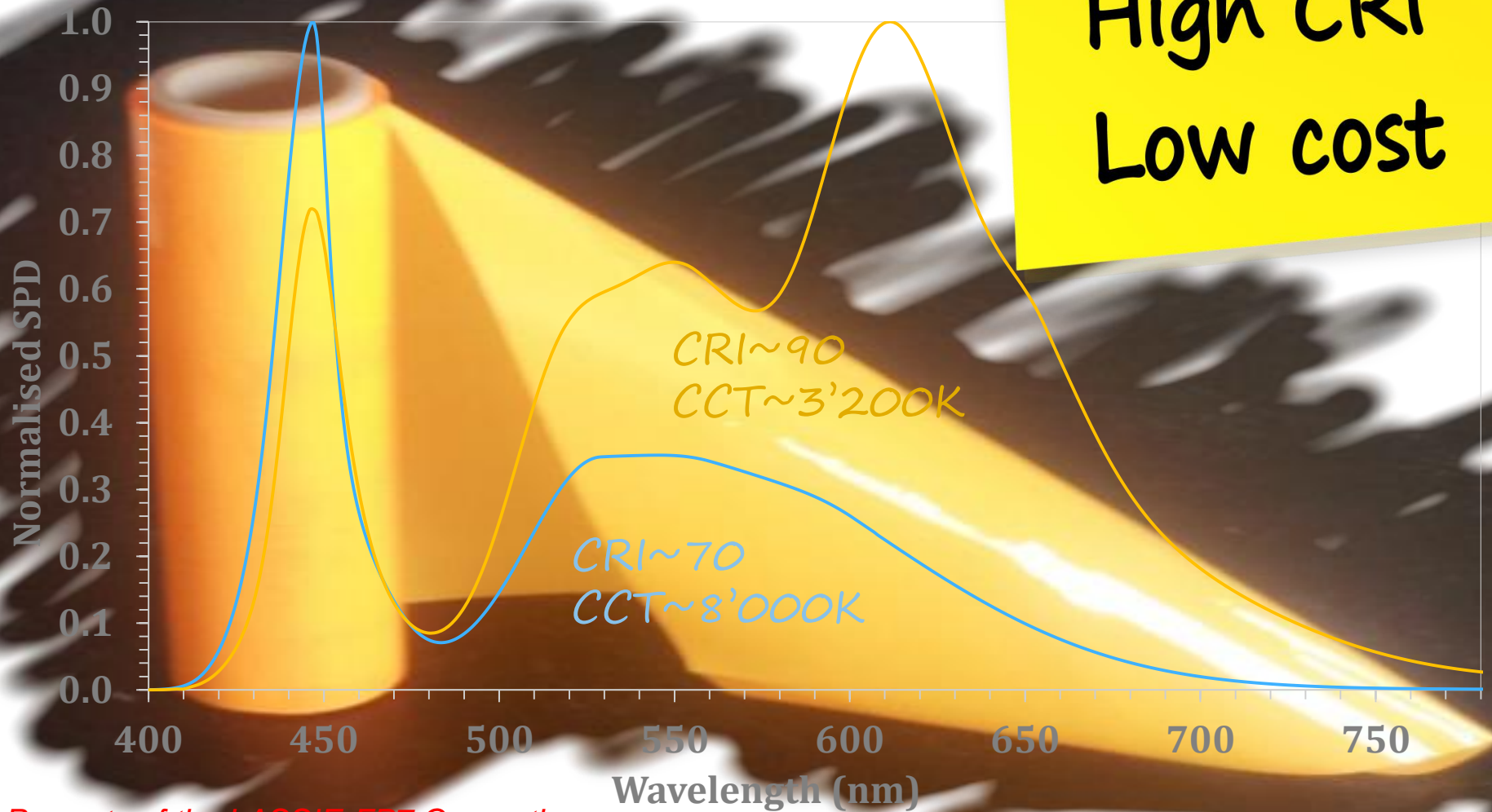

Property of the LASSIE-FP7 Consortium

Thank you

